



# 13 - Waste Water System

---

The waste water system in your motorhome consists of two primary components: one gray water holding tank and a 50-gallon solid (black water) holding tank. In addition, the system consists of a dump valve for each holding tank, a final manual dump valve at the waste connection, a black water holding tank flush system, the toilet, "P" traps at each sink and shower drain, and an indicator on the monitor panel for each tank. Each tank is vented through the roof. A garbage disposal unit is installed in the galley sink.

The water in the "P" traps prevents odors from passing through the traps and venting into the motorhome interior. Evaporation, particularly in a little used shower can make the "P" trap ineffective and allow odors to back up into the motorhome interior. Make sure there is water in the traps.



## **CAUTION**

Do not use roto-type equipment or caustic type cleaners to clean plastic drain traps. They may damage the plumbing.

Whenever the waste system is not connected to a sewer receptacle, the dust cap should be kept on the drain connection to prevent dust and/or dirt from entering the connection and damaging the dump valves.

## *Holding Tanks*

The holding tank provides maximum flexibility and convenience for complete self-contained operation. The holding tank stores water that has been used in the galley and bathroom sinks, shower/tub, and washer (if installed).

The solid waste holding tank stores only waste from the toilet. Both tanks terminate at a three-inch drain fitting inside the water utility compartment.

Each holding tank has a separate dump valve. The dump valve is a quick opening, knife-type, slide valve.

**NOTE:** Do not open the holding tank dump valves unless properly connected to a sewer receptacle.

**NOTE:** To assure a satisfactory flush of solid wastes into the holding tank, use plenty of water for the flush. To help disperse solid wastes into the tank, pre-charge the tank with 6-8 gallons of water after each holding tank dumping. This will help prevent buildup of solid wastes that might cause clogging.



# Waste Water System

13-2

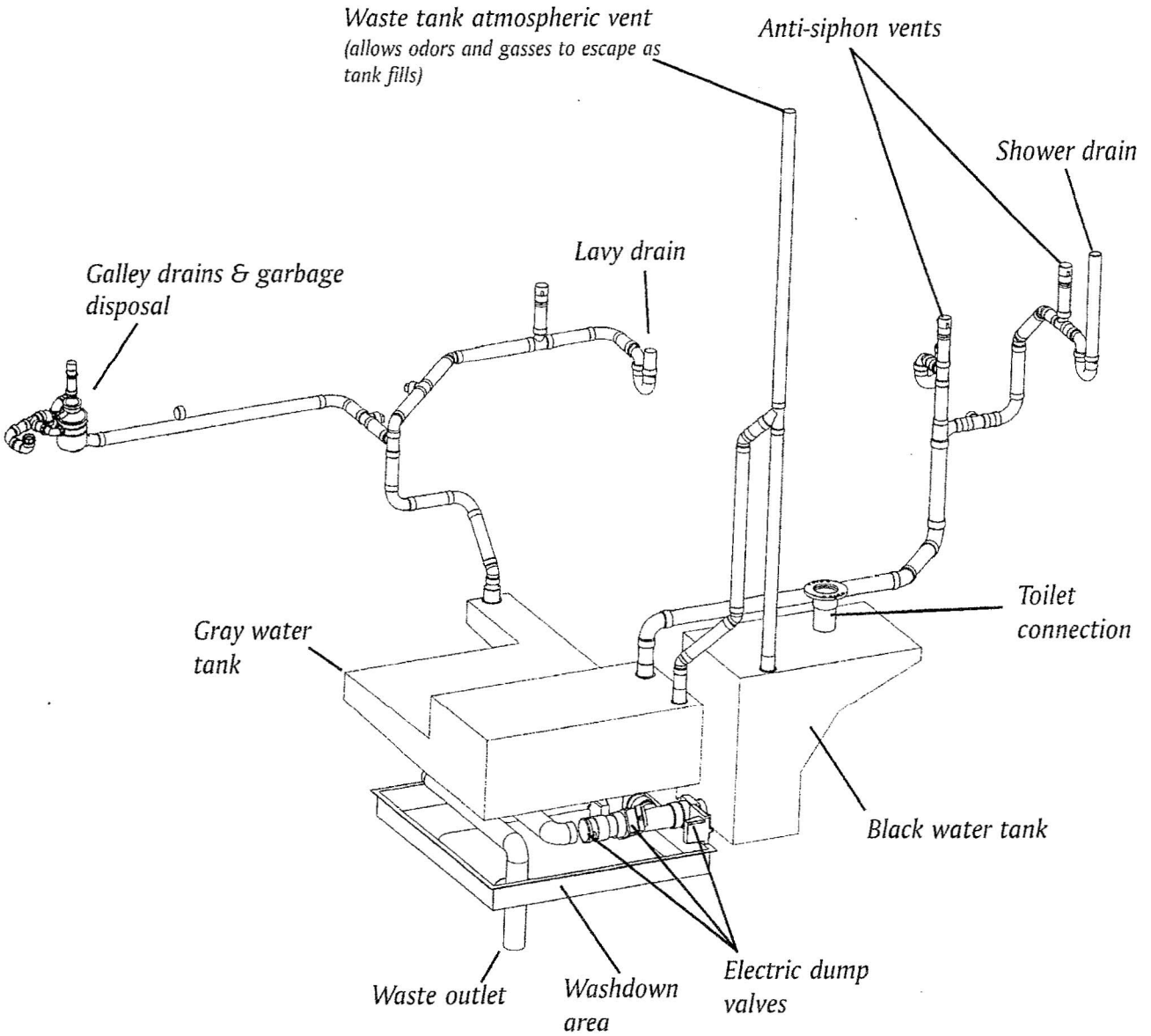

## Waste Water System Plumbing



Each waste tank is made of seamless molded plastic, and is free of corrosion problems. To insure proper operation of the toilet, dump valves, monitor, and holding tanks, never flush the following items down the toilet.

Facial and/or wet strength tissues

Colored toilet paper. Use the inexpensive white toilet tissue as it dissolves easily. Biodegradable tissue is recommended and available at RV supply stores.

Detergent or lye

Petroleum products or ammonia

Cooking type grease or oil

Use only potable antifreeze products, which are approved by the toilet and tank manufacturers, when winterizing the motorhome.

**NOTE:** Prime the waste holding tank with an odor control chemical and one or two gallons of water at the start of each trip. Vehicle movement helps to liquefy solids for easier dumping.

### *Holding Tank Monitor*

The level in each holding tank is indicated on the monitor panel. To check the level, press the switch for the tank and check the indicator light.

### *Electric Dump Valves*

The electric dump valves operate off the house 12-volt DC system. They are controlled by rocker switches located in the water utility compartment. To operate, set the rocker switch to **OPEN** or **CLOSE** position.

In case of electrical failure, the dump valves can be opened manually:

1. Remove the hex bolt, locknuts, and hex extension.
2. Grasp the threaded handle rod with pliers or similar tool and pull the threaded handle rod up through the mounting hole in the rack gear.



## Waste Water System

---

13-4

### *Toilet*

The toilet is manually operated by two foot pedals. The left pedal flushes the toilet by opening the valve in the bottom of the toilet. The right pedal opens the water valve to allow water into the toilet.

When flushing the toilet, make sure all contents are flushed out. If toilet tissue gets caught between the seal and the valve, the toilet may allow odors from the holding tank into the interior of the motorhome.

### *Operation*

Depress the water fill pedal to fill the toilet bowl prior to use.

Depress the flush pedal to flush the contents into the holding tank.